

FEV SUPPLIER ASSESSMENT

FEV SUPPLIER ASSESSMENT –
A PROVEN AND PRACTICE-ORIENTED MIX OF
SUPPLIER AUDIT, ASSESSMENT AND DUE DILIGENCE

13

KEY MEASURES FOR
FURTHER OPTIMIZATION

>120

PAGES OF DETAILED
ASSESSMENT REPORT

3

DAYS ONSITE
ASSESSMENT

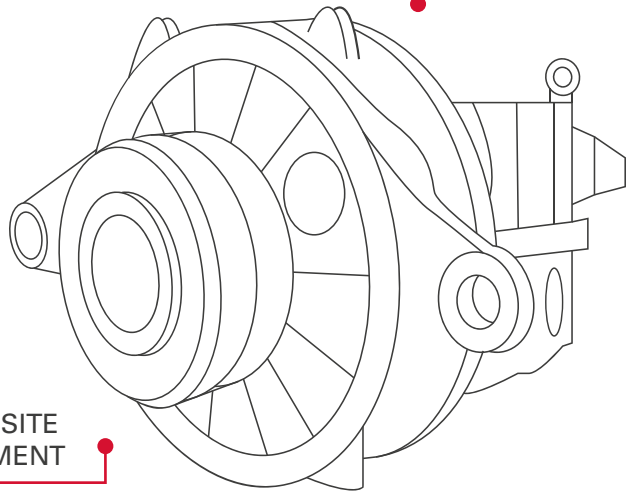

SITUATION & APPROACH

RESULTS AND BENEFITS

- An internationally operating wind mill manufacturer asked for support in evaluation of a Chinese main gear box supplier
 - FEV Consulting had the mandate to perform the onsite assessment with focus on R&D, production, quality and supply chain management processes
 - Data collection and supplier screening (outside-in) with initial supplier profile
 - Adaption of FEV Consulting assessment framework to specific company and customer demands
 - Onsite assessment of Chinese main gearbox supplier with focus on value creation processes (R&D, production, quality and SCM)
 - Shop floor visits and interviews with management and key stakeholders in order to evaluate supplier capabilities and maturity level
 - Preparation of a detailed report with evaluation of existing processes, facilities and knowhow, including an optimization roadmap for further supplier development
- Deep insight view on existing business processes and performance
 - Evaluation of supplier capabilities, quality and maturity level
 - Identification of key issues, risks and development of an optimization roadmap



#SUPPLIERASSESSMENT #R&D-PROCESSES #LEANPRODUCTION #QUALITYMANAGEMENT



SMART COST REDUCTION

In order to significantly save costs on technical products, FEV experts from different areas proceed in an interdisciplinary manner. They make detailed analyses of existing cost drivers, benchmark products from competitors, and generate a calculation of target costs from the bottom up. In addition, they generate innovative solutions for

cost reduction through Value Engineering and implement them by way of international sourcing — or commercially, through supplier management — at the required quality level. FEV extensively trains client employees and installs proven methods and tools. This ensures the achieved savings in the long term.

Dipl.- Ing.- MBA.

CHRISTIAN SPEUSER

Principal

FEV Consulting GmbH
Neuenhofstr. 181
52078 Aachen

Tel.: +49 (0) 241 / 5689 9973
Mobil: +49 (0) 172 / 200 1062
E-Mail: Christian.Speuser@fev.com
Internet: www.fev-consulting.com

SERVICE LINES OF FEV CONSULTING



Technology
Roadmapping



Connected and
Automated Driving

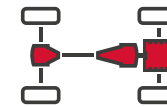

Powertrain
Concept Studies



Modularization
Strategies

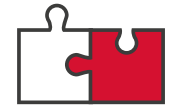

Mergers &
Acquisitions

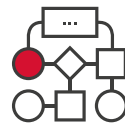

Product Development &
Process Optimization



Vehicles &
Lightweight



Smart Cost
Reduction

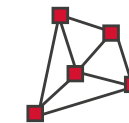

Manufacturing
4.0



Supply chain
management