

SMART COST REDUCTION

>1500
PARTS
ANALYZED

>120
COST
REDUCTION
IDEAS

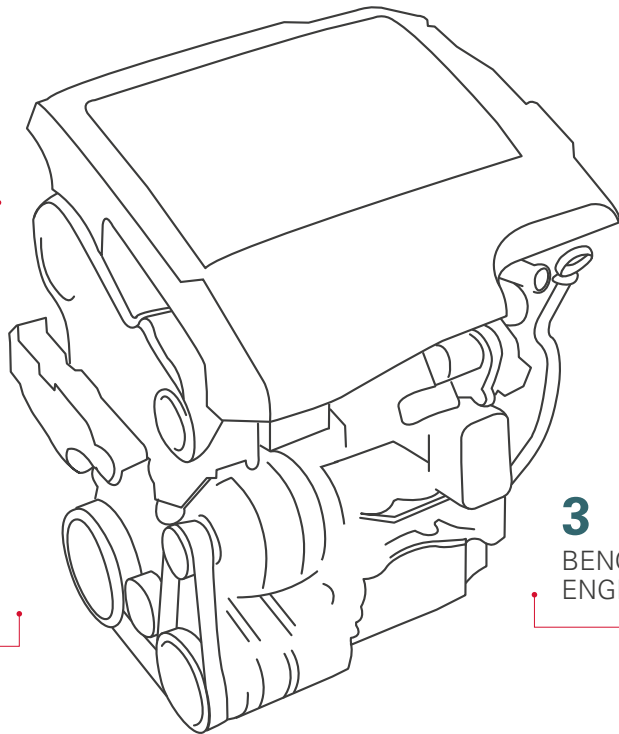

3
BENCHMARK
ENGINES

15%
SAVINGS



SITUATION & APPROACH

- A passenger car manufacturer is looking for significant cost reduction potential regarding its engine family
- Objective is to reduce the engine costs 10% to 15% by a structured cost & value engineering approach
- Detailed analysis of current cost structure according components and functions
- Tear down and benchmarking of three competitor engines
- Carry out several interdisciplinary cost down workshops with FEV experts
- Documentation and evaluation of all cost down ideas in a comprehensive idea data base
- CAD redesign of selected components
- Carry out a structured sourcing process regarding selected items and ideas to receive market prices
- Knowhow transfer and training of clients staff



RESULTS AND BENEFITS

- >120 cost reduction ideas
- About 15% cost reduction potential
- Realization of first quick wins
- Training of clients staff in methods & tools



SMART COST REDUCTION

In order to significantly save costs on technical products, FEV experts from different areas proceed in an interdisciplinary manner. They make detailed analyses of existing cost drivers, benchmark products from competitors, and generate a calculation of target costs from the bottom up. In addition, they generate innovative solutions for cost reduction through Value Engineering and implement them by way of international sourcing — or commercially, through supplier management — at the required quality level. FEV extensively trains client employees and installs proven methods and tools. This ensures the achieved savings in the long term.

SERVICE LINES OF FEV CONSULTING



Technology Roadmapping



Connected and Automated Driving

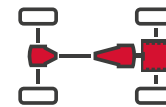

Powertrain Concept Studies



Modularization Strategies



Mergers & Acquisitions

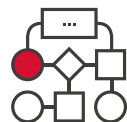

Product Development & Process Optimization



Vehicles & Lightweight



Smart Cost Reduction

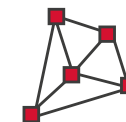

Manufacturing 4.0



Supply chain management

Dipl.- Ing.- MBA.

CHRISTIAN SPEUSER

Principal

FEV Consulting GmbH
Neuenhofstr. 181
52078 Aachen

Tel.: +49 (0) 241 / 5689 9973
Mobil: +49 (0) 172 / 200 1062
E-Mail: Christian.Speuser@fev.com
Internet: www.fev-consulting.com